

INSTRUCTION MANUAL: YARDGARD

I. INTRODUCTION

Bird-X, Inc. has been recognized worldwide as the bird and pest control experts since 1964.

II. WHY CONTROL PESTS?

- Droppings are unsightly, unhealthy, and potentially fatal.
- Droppings cost money and time. "Cleaning up" represents costs unrecoverable by revenues.
- Pests are destructive and deface property.
- USDA, OSHA, health boards and other organizations can cite, fine or shut down companies for pest mess problems.

III. PEST MANAGEMENT PROGRAM

A. Survey the pests and their entry, exit and feeding habits.

B. Inspect your property. Discover what the pests find attractive about your area, and if the same conditions prevail in neighboring properties.

C. Remove inducements including food sources and shelter. Clean the area of all evidence of pests and the residual scent. Because pests and their droppings can cause many diseases, use extreme caution when removing them. Do not breathe or come into direct contact with them. If you have questions about how to do this safely, consult an expert. Remove food spillage, garbage, nesting material and other appealing items.

D. Maintain a clean and changing environment. For maximum effectiveness, periodically repeat C) above and relocate or reposition the unit, vary the output, or turn it off for a short time.

E. Install early. It is always best to install the YardGard before "pest season" begins, as it is easier to discourage them than to rout them out once they have already established a pattern.

F. Use products synergistically. Two or more different kinds of devices (YardGard plus netting and/or a taste or smell aversion) will produce a synergistic effect --i.e., in combination, the products will yield much greater effectiveness than the YardGard alone. Contact Bird-X, Inc. for information on "companion" products.

G. Consider alternate locations. Make educated guesses as to where the pests will go when they leave their current infestation area, and consider purchasing units to cover these areas as well.

IV. UNIT OVERVIEW

This adjustable-frequency, dual-operation, weatherproof unit deters deer, armadillos, rodents, cats, dogs, bats and raccoons. An infrared motion sensor is built in.

V. UNIT SET-UP

Gently pull off the back cover. Set the operation switch (upper right) to OFF.

Turn the frequency dial (upper left) to the desired pest.

On the operation switch, choose "MS AC or Battery" for the unit to operate briefly each time the motion sensor is tripped (works with both an AC adapter and batteries), or choose "CONT. AC Only" for the unit to operate continuously (works with an AC adapter only).

Turn "Sensitivity" dial to adjust motion sensor sensitivity.

AC Adapter Plug one end into the port underneath the operation switch and the other into any standard outlet. (If using outside, protect the outlet from weather). Run the cord through the notch on the bottom of the unit. Snap the cover back into place.

Batteries Install four "C" batteries as shown on the unit. Snap the cover back into place.

Expect coverage up to 4000 square feet in a generally oval pattern approximately 80 feet out in front of the unit, 50 feet wide. The speaker projects sound on a horizontal plane in one direction. The lower the sound frequency (clockwise), the greatest coverage. In dense foliage and/or large acreage, multiple units may be necessary.

SUCCESSFUL LONG-TERM BEHAVIOR MODIFICATION

YardGard success takes time to build. Pest habits may take several days or weeks to break. Follow all suggestions for maximum efficacy.

"Instant" tests on pets do not replicate natural conditions and give no indication of the unit's success with wild or visiting domesticated pests.

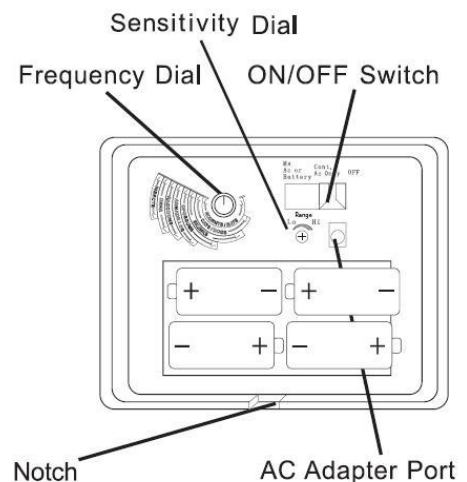

VI. INSTALLATION

Use the keyhole slots on the back to mount it on any building, wall or wooden post with nails or screws. Point the speaker at the area you want covered. If installing outdoors, place the unit at least 3 feet above the ground for optimum range.

VII. TROUBLESHOOTING

- A. Check that the power switch of the unit is not OFF (in other words, either CONT AC Only or MS AC or Battery). If using batteries, check that they are good. If using the Continuous AC Only power setting, check that the outlet is good. If using the MS AC or Battery setting, only expect activation if there is motion.
- B. Reread the Pest Management Program section above. Check for and remove unusual incentives.
- C. Check the dial settings and ensure you have selected a range appropriate to the pest.
- D. If a specific dial setting causes a squeaking or scratching sound, rotate the dial slightly until the sound stops.
- E. It is not unusual to hear a "chirping" noise when the motion sensor is tripped and the high frequency sound turns on and off.

VIII. PRECAUTIONS

Even though the top range of the YardGard, 25 kHz, is above human hearing range (which averages, at top level, about 16 kHz), the intensity is great enough to present a chance of damage to the ear if it is directly exposed for an extended period of time at a distance of less than 10 feet. These units should definitely not be located at or near a place where someone will be located for a long time. Normally, this type of unit is located outside pointing away from a house or structure, or indoors in a rarely occupied attic or basement, and thus presents no problem when located in this manner.

We suggest that when you are sitting or working within range of the unit, you turn it off, as human presence will normally deter the pests.

As with any electrical device, do not place the unit in or near water and do not mount it while standing in or surrounded by water.

Do not aim the product into neighboring yards or public areas, or at caged or leashed animals.

It is intended for use on your own property only. Some people with good high frequency hearing will be able to hear the unit at its lower frequencies. If this occurs, select a higher frequency.

IX. MANUFACTURER'S WARRANTY

The YardGard is warrantied against defects in materials and workmanship for a period of six months from the shipping date. At the option of Bird-X, Inc., we will either replace or repair the defective unit. Prior authorization and a returned goods authorization (RGA) number will be necessary from Bird-X, Inc.

RETURNS ARE ACCEPTED ONLY WITH AUTHORIZATION FROM OUR CHICAGO OFFICE.

X. SYNERGY AND OTHER PRODUCTS

For best results, Bird-X, Inc. always recommends that the YardGard be used in conjunction with one or more other products. The combination of different types of control methods has proven to maximize the effectiveness of pest animal control programs.

Visit www.bird-x.com for more information on companion products.

Copyright 2006 by Bird-X, Inc. All rights reserved.

SPECIFICATIONS

Power Supply: 4 x 1.5V "C" batteries
120 V AC adapter (if a different voltage adapter is needed, please purchase locally)
Note: when using an AC adapter, the unit will automatically switch to battery (if batteries are in) during a power failure.
Working Current: <200 mA
Motion Sensor Activation: up to 35 x 70 feet.
Frequency: 15 kHz -25 kHz (adjustable)
Effective Range: up to 4,000 square feet
Output Sound Pressure: 90 dB @ 1 meter



Chicago, IL 60607 USA

www.bird-x.com